

ORIGINAL ARTICLE

The effect of surface charge, negative and bipolar ionization on the deposition of airborne bacteria

S. Meschke¹, B.D. Smith¹, M. Yost¹, R.R. Miksch², P. Gefter³, S. Gehlke³ and H.A. Halpin⁴

¹ Department of Environmental & Occupational Health Sciences, School of Public Health & Community Medicine, University of Washington, Seattle, WA, USA

² IEH Laboratories & Consulting, Inc., Lake Forest Park, WA, USA

³ MKS Ion Systems, Alameda, CA, USA

⁴ Center for Health and Public Policy Studies, University of California, Berkeley, CA, USA

Keywords

air ionization, bioaerosol, environmental health, surface charge.

Correspondence

Scott Meschke, Department of Environmental & Occupational Health Sciences, School of Public Health & Community Medicine, University of Washington, Seattle, WA 98195, USA. E-mail: jmeschke@u.washington.edu

2008/0915: received 28 May 2008, revised 14 August 2008 and accepted 12 September 2008

doi:10.1111/j.1365-2672.2008.04078.x

Abstract

Aims: A series of experiments were conducted to evaluate the effect of surface charge and air ionization on the deposition of airborne bacteria.

Methods and Results: The interaction between surface electrostatic potential and the deposition of airborne bacteria in an indoor environment was investigated using settle plates charged with electric potentials of 0, ± 2.5 kV and ± 5 kV. Results showed that bacterial deposition on the plates increased proportionally with increased potential to over twice the gravitational sedimentation rate at +5 kV. Experiments were repeated under similar conditions in the presence of either negative or bipolar air ionization. Bipolar air ionization resulted in reduction of bacterial deposition onto the charged surfaces to levels nearly equal to gravitational sedimentation. In contrast, diffusion charging appears to have occurred during negative air ionization, resulting in an even greater deposition onto the oppositely charged surface than observed without ionization.

Conclusions: Static charges on fomite surfaces may attract bacteria resulting in deposition in excess of that expected by gravitational sedimentation or simple diffusion. Implementation of bipolar ionization may result in reduction of bacterial deposition.

Significance and Impact of Study: Fomite surfaces are important vehicles for the transmission of infectious organisms. This study has demonstrated a simple strategy for minimizing charge related deposition of bacteria on surfaces.

Introduction

Bioaerosols can be generated by several means in an indoor setting, such as the ventilation or air conditioning systems, dust or shed skin disturbance, coughs and sneezes, among others. Although the contribution of airborne micro-organisms to hospital or clinical-acquired infection has been the source of much debate in recent years, there is evidence suggesting that bioaerosols may play a greater role than previously believed (Schaal 1991; Beggs 2003). It has been estimated that the amount of skin squamae shed from hospital staff, visitors and patients equals approx. 3×10^8 per day, and an average of four viable bacteria per skin scale has been found in

hospital wards (Lidwell *et al.* 1959; Noble 1981). Duguid showed as early as 1945 that a sneeze can release hundreds of thousands of droplets into the air at speeds in excess of 200 miles per hour; and a cough, although producing only about 1% of the amount of airborne droplets as a sneeze, occurs much more often (Duguid 1945). Larger droplets settle out of the air quickly, and relatively close to the generation point, but coughing and/or sneezing can produce a large concentration of droplets less than $2 \mu\text{m}$ in size that resist evaporation, and are capable of transmitting disease-causing micro-organisms over much longer distances (Papineni and Rosenthal 1997). Shiomori *et al.* (2002) demonstrated how hospital activities, such as bedmaking, caused significant aerosolization

of methicillin-resistant *Staphylococcus aureus*, which reinforced a similar study conducted by Overton (1988).

Mainelis *et al.* (2001) revealed that the process of aerosolizing and dispersing bacteria can induce an electric charge around the cell wall as high as 13 000 elementary electric charges, greatly overwhelming the microbe's natural charge and causing their drift velocity to increase (Mainelis *et al.* 2001, 2002). In contrast, they found that nonbiological particles accumulated only low levels of electric potential when aerosolized by the same method.

Considering what is known about attraction and repulsion effects of other charged particles, it is a logical hypothesis that bioaerosols charged above the Boltzmann equilibrium will be attracted towards oppositely charged objects or surfaces in excess of normal sedimentation or diffusion. Indeed, Allen *et al.* (2006) showed in a recent pilot study that nurses' polypropylene aprons, along with various other plastic materials often used in healthcare settings every day, generated an electric field from static charge buildup, and collected much higher numbers of micro-organisms than aluminum foil aprons. Some articles worn by healthcare professionals could generate an electric field surrounding the patients, facilitating an attraction of potentially pathogenic microbes and contributing to nosocomial infections.

Similar conclusions were drawn by Becker *et al.* (1996), who observed that when surgeons perform endoscopic surgery, they frequently point to a video monitor for emphasis. They found that bacteria grew from the cultures when a gloved hand passed within 4 cm of the monitor, and did not grow beyond 8 cm distance, suggesting that the electrostatic field generated between the video screen and the gloved finger might be a mechanism contributing to bacterial contamination.

Some electrostatic control measures have been discussed in the literature as well. Cozanitis *et al.* (1988) sprayed an antistatic solution on several materials and surfaces in an intensive care ward and then measured the amount of static charge that accumulated, compared with other materials that were left untreated. The surfaces were then sampled for aerobic bacterial deposition. Although spraying the entire room did not significantly reduce bacterial contamination, results suggested that focusing antistatic solution on insulating objects, where buildup of static charge occurs, would reduce electrical resistance, and subsequent airborne bacterial contamination. Makela *et al.* (1979) reported a smaller bacterial concentration in air after using a negative ion generator in a Burns and Plastic Surgery Unit. Also, Gabbay *et al.* (1990) noted a 40–50% reduction in microbial air pollution after employing a 13.5 kV (polarity unspecified) corona-type ion generator every second week in a dental clinic. Similar types of studies have been conducted for

nonbiological particles in the semiconductor industry. Successful engineering controls that have been developed for clean room environments are based on the theory that the reduction of electrostatic attraction and discharge on surfaces are directly responsible for controlling the deposition of airborne particulate matter (Cooper *et al.* 1990).

In recent years, air ionization has been successfully marketed as a method for removing contaminants from air. Numerous ion generators are available in many sizes and emission capabilities for both commercial and home applications. However, there has been some controversy regarding the performance of commercial ionic air purifiers (Grinshpun *et al.* 2005).

This study investigated the effect of electrostatic attraction (ESA) on deposition of airborne bacteria on surfaces by first exposing them to a test surface with electric potentials of ± 2.5 kV and ± 5 kV in an indoor setting, and then comparing the deposition to gravitational sedimentation (found at a 0 kV grounded surface). Additionally, this study examined the effect of increasing the air ion density (negative and bipolar) in the test environment on the reduction of airborne bacterial deposition.

Materials and methods

Test environment

The study was conducted in a men's restroom of a university research building. The restroom contained one toilet, one urinal, and one handwashing sink, in an overall volume of 29 m³. Preliminary sampling showed that this room could be relied upon to offer sufficient levels of airborne bacteria to yield statistically useful results. Airflow in the room was dominated by the building's HVAC (heating, ventilation and air conditioning) system. The temperature (70–72°C) and humidity (32–34%) for the test environment were centrally controlled.

Test apparatus and agar plates

A rectangular test platform was designed with a laminate-covered thin wood surface approx. 1.27 m in length by 0.6 m width, positioned at a height of 0.6 m. Four strips of 5 cm-wide electrically conductive foil tape were placed on the surface, separated 20 cm apart from a central 10 cm-wide grounded strip (Fig. 1). The centre ground strip had two main purposes. The first was for collection of normal sedimentation rates and the second was to terminate the electric field, preventing one side of the apparatus from adversely affecting the other. One power supply provided positive electric potential up to +5 kV to the left two conductive strips, while a second power

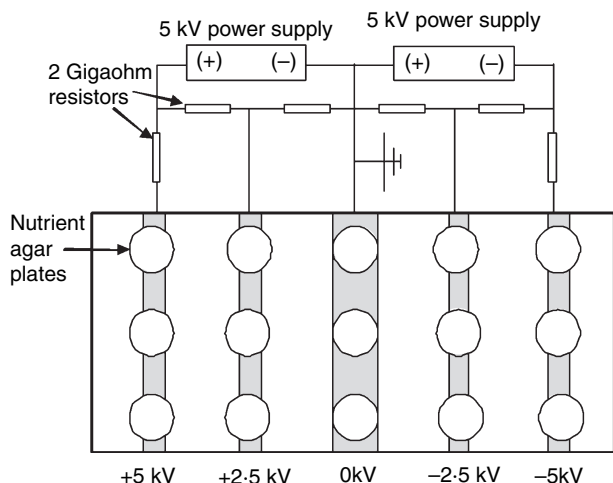

Figure 1 Overhead diagram of the test surface, electrical schematic and placement of nutrient agar plates. The surface measured 1.27 m in length by 0.6 m width, the centre grounded conductive foil strip measured 10 cm wide, the other four strips measured 5 cm wide. The conductive strips were each separated by approx. 20 cm.

supply provided negative potential up to -5 kV to the right two strips. A voltage divider network of 2 G Ω resistors was used to establish the ± 2.5 kV potential on each side, and to provide current limiting of the power supplies to minimize the shock hazard. The power supplies each contained a switch that allowed the polarities on the test apparatus to be reversed as needed. A 1.27 m by 0.6 m section of wire mesh screen was fixed approx. 30.5 cm above the surface of the apparatus to provide a reference ground plane and ensure a steady electric field during testing. The modelling basis for the design of the test apparatus including electric potential selection and strip spacing has been previously described by Miksch *et al.* (2008).

Three evenly spaced 100 \times 15 mm nutrient agar Petri plates were placed on top of each conductive electrical strip, for a total of 15 per test. Nutrient agar was selected for this study, as it is widely used general purpose medium for the culture of nonfastidious micro-organisms (Difco Laboratories, 1998). Each plate was prepared with 35–40 ml of agar, to account for evaporation that occurs when exposing the plates to the air for extended periods of time. A 10 cm length of 0.4 mm thickness nickel–chromium wire was wrapped from the underside of each Petri plate, around the side and into the nutrient agar so that the electric potential in the agar matched that of the corresponding electrical conductive strips. The electric potential on the agar plates was measured with a non-contacting electrostatic field meter (model M770, MKS Ion Systems, Alameda, CA), and was identical to the potential on the foil strips.

To detect horizontal movement of airborne bacteria from one side of the test apparatus to the other, a series of tests were conducted replacing the three nutrient agar plates on the central grounded strip with back-to-back plates attached in the vertical ground plane at the centre of the apparatus on a flow-through stand at a height of 15 cm above the test surface. Electric field modelling indicated that at this location, the electric field has a strictly horizontal component oriented from the positive to negative side of the apparatus. The vertical plates were spaced from front to back in the same manner as the surface plates and attached to the central grounded strip to ensure that they remained at ground potential during testing.

Ionization experiments

A Comtech Research Model IG-133A negative ion generator (Cantech Research LLC, South Greenfield, MO) and an MKS Ion Systems Model 6442 bipolar ionizer were used for air ionization experiments. Both were corona-discharge type ionizers, each releasing greater than 10^5 ions/cm³. An ion counter was used to determine a suitable location in the restroom for the ionizers and how long they needed to run before starting each test. The ionizers were placed approx. 1 m away from the apparatus, at a height of 0.9 m and were operated for the duration of each exposure period. Five trials were conducted under similar conditions as the previous ESA experiments with each ionizer.

Sampling strategy and analysis

Ten test runs were conducted comparing bacterial deposition rates at electric potentials of increasing magnitude to normal sedimentation rates. Nutrient agar Petri plates were exposed to the air for 24 h. At the same time, electric potentials of +5 kV, +2.5 kV, 0 kV, -2.5 kV and -5 kV were applied to the conductive strips and agar plates from left to right on the test surface, as shown in Fig. 1. Electric potentials were verified before, during and after each test by a non conducting electrostatic field meter. To provide a balanced sampling scheme, and account for possible airflow anomalies caused by the irregular shape of the restroom, and/or disturbance caused by frequent movement of the restroom door, the polarities on the test apparatus were reversed for half of the tests.

Additionally, five vertical plate tests were conducted to evaluate horizontal movement of bacteria across the test apparatus, followed by two more tests with no electric field. The tests with no electric field were used for comparison with data collected from the 0 kV strip

during regular testing, and to verify there was nothing inherent in the test apparatus design or placement in the restroom causing differential deposition of airborne bacteria to occur. Finally, five tests were conducted each with negative and bipolar ionization. For the ionization experiments, the ion generators were turned on 15 min prior to the start of the test and run continuously until the end of each sample period.

Upon conclusion of each round of tests, the Petri plates were incubated at 37°C for 48 h, followed by enumeration of colony forming units (CFUs). Because of significant variation in bioaerosol concentration in the restroom between trials, the data collected for each trial were standardized relative to the 0 kV potential for that trial. Results are reported as the overall median of the ratios of the average CFU/plate at each electric potential relative to the average CFU/plate at 0 kV, (\pm) median absolute deviation (MAD).

Statistical analysis

Kruskal–Wallis ANOVA by Ranks tests were used to evaluate differences between multiple electric potentials for a group of test runs and Wilcoxon Matched Pairs tests were performed to evaluate specific relationships between charged electric potentials and the 0 kV grounded potential. Kruskal–Wallis tests were also used to evaluate differences between ESA and both ionization schemes for individual potentials. Mann–Whitney *U*-tests were performed to examine specific relationships between the ESA runs and either negative or bipolar ionization runs for each potential. Tests with *P*-values ≤ 0.05 were considered statistically significant. All statistics were performed using the Statistica software package, release 6.1 (Statsoft, Inc., Tulsa, OK, USA).

Bacterial identification

Selected bacterial colonies of distinct morphotypes isolated during the study were Gram stained, oxidase and catalase tested, and then phenotypically identified using a carbon source metabolic fingerprinting technique (Biolog Inc., Hayward, CA, USA).

Results

Empirical deposition rates from ESA tests

Nearly a 2.5-fold increase in median bacterial deposition at +5 kV surface potential relative to the 0 kV ground was observed for test runs without air ionization. A comparison of the underlying CFU per plate per hour data at these potentials indicated the difference was statistically

Table 1 Median bacterial deposition (CFU per plate) ratios at each surface potential relative to 0 kV for ESA, Negative Air Ionization, and Bipolar Air Ionization

Experiment type	+5 kV	+2.5 kV	0 kV	-2.5 kV	-5 kV
ESA w/No Ionization†	2.48	1.635	1	1.17	1.51
MAD	0.17	0.13	0	0.12	0.23
Negative Air Ionization‡	3.08	2.09	1	0.84	0.86
MAD	0.37	0.19	0	0.14	0.26
Biopolar Air Ionization‡	1.03	1.02	1	1	1.01
MAD	0.04	0.01	0	0.03	0.03

†Median values from ten trials.

‡Median values from five trials.

MAD, Median Absolute Deviation.

significant ($P < 0.05$). A significant increase also was seen at the -5 kV potential, although the bacterial deposition on the negative side of the test apparatus was considerably lower compared with deposition observed on the positive side ($P < 0.05$). Furthermore, a proportional bacterial deposition was observed for the ± 2.5 kV potentials. Table 1 summarizes the bacterial deposition ratios at each surface potential compared with gravitational sedimentation.

An average of 45 CFU per plate was found at the 0 kV conductive strip when electric charge was applied to the test apparatus over the course of all exposure periods. When tests were conducted in the absence of charge being applied, the average CFU count per plate was 46. This confirms both the model discussed in Miksch *et al.* (2008) and fieldmeter measurements, which demonstrated effective separation of the electric fields on both sides of the test apparatus, preventing each side from adversely affecting the other during testing and providing a 'corridor' for bacteria not charged above the Boltzmann equilibrium to deposit solely via gravitational forces.

Vertical plate tests (horizontal movement)

For vertical plate tests, experimental conditions were similar to the ten original ESA experiments conducted without ionization. Bacterial counts collected from vertical agar plates were standardized according to average CFU per plate per hour. The resultant number of bacteria moving from the (-) side of the test apparatus to the (+) side was 0.26 CFU per plate per hour. This was more than 1.6-times higher than the 0.16 CFU per plate per hour found moving from the (+) side to the (-) side. These results are consistent with the ratio of median deposition between the +5 kV and -5 kV potentials found in the first series of ESA tests (1.64), once again illustrating that not only electrostatic interactions are

occurring, but there is also a net higher concentration of negatively charged bacteria in the test environment, further supporting results found in other studies (Wilson et al. 2001; Lee et al. 2004).

Negative ionization experiments

The results of negative air ionization, as shown in Table 1, clearly indicate a significant reduction of bacterial deposition on the negative side of the test apparatus ($P < 0.002$), resulting in deposition nearly equal to that of gravitational sedimentation. This is consistent with the notion that increasing the air ion density reduces the potential on oppositely charged airborne bacteria towards the Boltzmann equilibrium prior to deposition, such that the bacteria in the present experiments were no longer carrying a positive charge and could not be attracted to the negative side of the test apparatus in excess of normal gravitational rates.

Most of the ratios at the negative surface potentials were <1.0 , suggesting a slight electrostatic repulsion effect, but the differences were not statistically significant. Additionally, there was a 24% median increase in deposition on the +5 kV conductive strip compared with the previous nonionization median value of 2.48, and a 28% increase on the +2.5 kV strip. Although these increases were similarly not statistically significant, the data are consistent with the occurrence of diffusion charging. In other words, it appears likely that there were enough negative ions remaining in the room after neutralizing any positive-charged airborne bacteria that diffusional collisions occurred between the remaining negative ions and the airborne bacteria, resulting in a net increase of negatively charged bacteria being repelled away from the negative side of the test apparatus and/or attracted to the positive side.

Bipolar ionization experiments

Just as the negative ionization experiments demonstrated reduction in bacterial deposition on the negative potential surfaces, the bipolar ionization experiments showed effective reduction of bacterial deposition onto all the test surfaces of either polarity. After adding bipolar ions in excess of 10^5 cm^{-3} for the duration of each exposure period, the resultant median ratios of CFU per plate per hour were almost identical across the entire apparatus, independent of the surface potential, within the MAD on most accounts (Table 1). Bacterial deposition from the first series of runs without ionization was reduced in the bipolar ionization tests, and was statistically significant at all potentials, excluding the reference value at 0 kV ($P < 0.02$). These results support the assumption that a

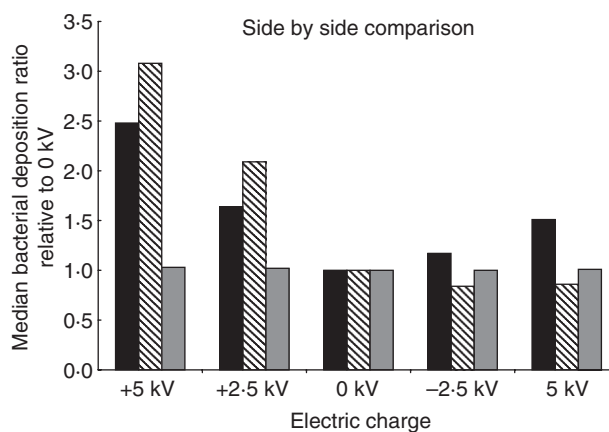

Figure 2 Graphical representation comparing bacterial deposition from ESA, negative and bipolar ionization tests. (■), Original ESA tests; (▨), Neg ionization; (■), Dual pol. ionization.

high concentration of bipolar ions in the test environment significantly reduces the charge decay time on airborne bacteria towards the Boltzmann equilibrium, as well as prevents diffusion charging from occurring.

The results of the electrostatic attraction, negative and bipolar ionization experiments on the deposition of airborne bacteria are also shown side-by-side graphically in Fig. 2. The graph is used to further illustrate that not only electrostatic interactions are occurring between charged bacteria and surfaces, increasing the air ion density in the test environment can be effective in reducing the number of bacteria attracted per unit area to oppositely charged surfaces.

Identification of selected bacteria isolates

Identified bacterial isolates were evenly distributed in both ESA and ionization experiments, and at all surface potentials. Six dominant colony types were observed on the agar plates. Bacteria isolated from these colony types included: *Micrococcus lylae*, *Micrococcus luteus*, *Micrococcus* genus (species not determined), *Staphylococcus delphini*, *Bacillus licheniformis* and *Moraxella osloensis*. *Micrococcus* spp., or bacteria having similar microscopic and colony morphologies, made up over 96% of the colonies enumerated. It is interesting that all bacteria identified were Gram-positive, with the exception of *M. osloensis*, which is a Gram-negative coccoid bacteria, and a known opportunistic pathogen. The occurrence of *M. osloensis* and *B. licheniformis* colony types was rare. An equally interesting observation, considering the test setting, was that *Escherichia coli* and *Staphylococcus* spp. other than *S. delphini* were not identified in this study.

Discussion and conclusion

Allen *et al.* (2006) demonstrated that moving an item carrying a static charge into close proximity of hospital patients could induce an electric field surrounding the patient, causing an excess of potentially harmful airborne micro-organisms to be attracted towards them. The results of this study clearly support the notion that electrostatic attraction can be a significant force affecting the deposition of airborne bacteria charged well above the Boltzmann equilibrium. Bacterial deposition in the present ESA experiments more than doubled when an electric potential of +5 kV was applied to the test surface. Deposition increased at the -5 kV potential as well, but to a lesser degree. Deposition increased substantially on both sides of the test apparatus, indicating that airborne bacteria carrying high charges of either polarity were present in the test environment. However, both nonionization and vertical plate tests showed that the bacteria were negatively charged to a greater degree, consistent with literature suggesting an overall tendency towards a net negative charge (Wilson *et al.* 2001; Lee *et al.* 2004).

As with other types of charged particles, electrostatic interactions likely are maintained as long as airborne bacteria carry a net electrostatic charge and remain in close proximity to an oppositely charged surface. Although the unit charge on the bacteria was not directly determined in the present investigation, deposition was seen to increase proportionally with increased magnitude of surface potential, a result that supports the assumption that airborne bacteria in the test environment were highly charged. As a charged bioaerosol has been reported to take <2 h to decay to the Boltzmann equilibrium under normal conditions (Hinds 1999), there was likely fresh generation of bioaerosols taking place in the test environment for the high charge state to occur on the bacteria. It follows then, that implementing methods that rapidly reduce the charge decay time on airborne bacteria, along with controlling the fresh generation of bioaerosols in the first place, should be integrated into schemes designed to address the threat of increased microbial contamination resulting from electrostatic interactions.

Charged particles will decay exponentially to the Boltzmann equilibrium, depending on how many elementary charges the particles carry, as well as the concentration of air ions in the surrounding environment. Increasing the air ion density above 10^5 ions cm^{-3} significantly reduced the decay time in ionization experiments. Unipolar ionization caused a reduction in deposition of oppositely charged bacteria to nearly equal that of normal sedimentation, but it also likely contributed to diffusion charging and greater deposition onto surfaces having the opposite polarity as the ions emitted. This suggests that employing

a unipolar ionization scheme might not always be a sufficient method of controlling airborne bacterial contamination. On the other hand, increasing the concentration of bipolar ions effectively reduced bacterial contamination across the entire test surface to normal sedimentation rates, independent of electric potential, which is consistent with the elimination of electrostatic attraction and diffusion charging.

One of the unexpected observations was the large preponderance of Gram-positive bacteria that had deposited on the test surface, and the relative absence of Gram-negative bacteria. Based on the location of the study (a high traffic men's restroom), *E. coli* and a greater number of *Staphylococcus* spp. were expected to be isolated from the agar plates. However, *E. coli* was not identified in this study and the only *Staphylococcus* species identified was *S. delphini*. Possible explanations could include sampling bias, differences in surface charge between organism types, interference from walls, distance from generation point, organism viability and level of occurrence. Some *Staphylococcus* spp. might have been missed because of their morphological similarities to *S. delphini*. Additional analysis is needed to further investigate these observations related to specific bacterial species.

It is important to note that the semiconductor industry has employed electrostatic-based engineering methods for many years to control particle deposition in clean room environments (Cooper *et al.* 1990). The results of this study suggest that similar ionization-type engineering controls could be employed to minimize surface charge in hospital settings, which may help reduce the potential for fomite disease transmission because of the deposition of bioaerosols. Our findings suggest that highly charged bioaerosols and materials used in the patient setting (e.g. plastics and electric equipment for monitoring or treating) may represent an important new avenue for exploration and research into reducing hospital acquired infections. Additional research is needed in hospital settings to test the effect of adopting electrostatic controls in the areas of hospitals where the patients most vulnerable to infections are being treated (e.g. intensive care rooms, burn units, oncology wards and surgical suites).

References

- Allen, J., Close, J.J. and Henshaw, D.L. (2006) Static electric fields as a mediator of hospital infection. *Indoor Built Environ* **15**, 49–52.
- Anonymous. (1998) *Electrostatic Compatibility: Guide to Assess and Control Electrostatic Discharge (ESD) and Electrostatic Attraction (ESA) for Equipment*. Mountain View, CA: Semiconductor Equipment and Materials International, Sept. 1998: SEMI E78-0998.

- Becker, R., Kristjanson, A. and Waller, J. (1996) Static electricity as a mechanism of bacterial transfer during endoscopic surgery. *Surg Endosc* **10**, 397–399.
- Beggs, C.B. (2003) The airborne transmission of infection in hospital buildings: fact or fiction? *Indoor Built Environ* **12**, 9–18.
- Cooper, D., Miller, R.J., Wu, J.J. and Peters, M.H. (1990) Deposition of submicron aerosol particles during integrated circuit manufacturing: theory. *Particulate Sci Technol* **8**, 209–224.
- Cozaniotis, D.A., Ojajarvi, J. and Makela, P. (1988) Antistatic treatment for reducing airborne contamination of insulating materials in intensive care. *Acta Anaesthesiol Scand* **32**, 343–346.
- Difco Laboratories. (1998) *Difco Manual*, 11th edn. Sparks, MD: Difco Laboratories, Division of Becton Dickinson and Company.
- Duguid, J.P. (1945) The size and the duration of air-carriage of respiratory droplets and droplet-nuclei. *J Hyg* **54**, 471–479.
- Gabbay, J., Bergerson, O., Levi, N., Brenner, S. and Eli, I. (1990) Effect of ionization on microbial air pollution in the dental clinic. *Environ Res* **52**, 99–106.
- Grinshpun, S.A., Mainelis, G., Trunov, M., Adhikari, A., Reponen, T. and Willeke, K. (2005) Evaluation of ionic air purifiers for reducing aerosol exposure in confined spaces. *Indoor Air*, **15**, 235–245.
- Hinds, W.C. (1999) *Aerosol Technology*, 2nd edn. New York, NY: Wiley Interscience.
- Lee, S.A., Willeke, K., Mainelis, G., Adhikari, A., Wang, H., Reponen, T. and Grinshpun, S.A. (2004) Assessment of electrical charge on airborne microorganisms by a new bioaerosol sampling method. *J Occup Environ Hyg* **1**, 127–138.
- Lidwell, O.M., Noble, W.C. and Dolphin, G.W. (1959) The use of radiation to estimate the numbers of microorganisms in air-borne particles. *J Hyg* **57**, 299–308.
- Mainelis, G., Willeke, K., Baron, P., Reponen, T., Grinshpun, S.A., Gorny, R.L. and Trakumas, S. (2001) Electrical charges on airborne microorganisms. *J Aerosol Sci* **32**, 1087–1110.
- Mainelis, G., Willeke, K., Baron, P., Grinshpun, S.A. and Reponen, T. (2002) Induction charging and electrostatic classification of micrometer-size particles for investigating the electrobiological properties of airborne microorganisms. *Aerosol Sci Technol* **36**, 479–491.
- Makela, P., Ojajarvi, J., Graeffe, G. and Lehtimaki, M. (1979) Studies on the effects of ionization on bacterial aerosols in a burns and plastic surgery unit. *J Hyg (Lond)* **83**, 199–206.
- Miksch, R., Gefter, P., Gehlke, S., Halpin, H.A., Meschke, J.S., Smith, B. and Yost, M. (2008) *Relationship Between Surface Electrostatic Potential and Deposition of Airborne Bacteria*. (Accepted for publication in *IEEE Transactions on Industry Applications*). New York: IEEE Industry Applications Society.
- Noble, W.C. (1981) Dispersal of microorganisms from skin. In: *Microbiology of Human Skin*, ed. Noble, W.C., 2nd edn. pp. 79–85. London: Lloyd-Luke Ltd.
- Overton, E. (1988) Bedmaking and bacteria. *Nurs Times* **84**, 69–71.
- Papineni, R. and Rosenthal, F. (1997) The size distribution of droplets in the exhaled breath of healthy human subjects. *J Aerosol Med* **10**, 105–116.
- Schaal, K.P. (1991) Medical and microbiological problems arising from airborne infection in hospitals. *J Hosp Infect* **18**(Suppl. A), 451–459.
- Shiomori, T., Miyamoto, H., Makishima, K., Yoshida, M., Fujiyoshi, T., Udaka, T., Inaba, T. and Hiraki, N. (2002) Evaluation of bedmaking-related airborne and surface methicillin-resistant *Staphylococcus aureus* contamination. *J Hosp Infect* **50**, 30–55.
- Wilson, W.W., Wade, M.M., Holman, S.C. and Champlin, F.R. (2001) Status of methods for assessing bacterial cell surface charge properties based on zeta potential measurements. *J Microbiol Methods* **43**, 153–164.